

# EDGE SIDE CHANNELS INSTALLATION MANUAL

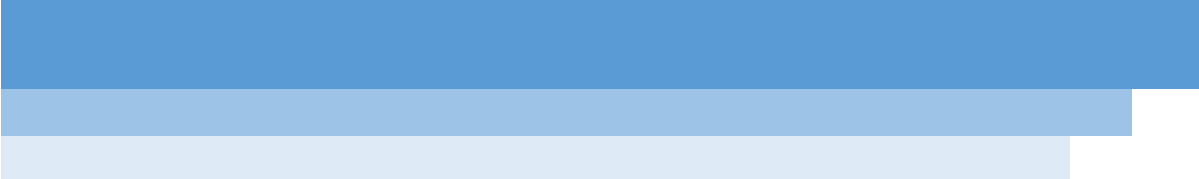

October 2017



# CONTENTS

October 2017

This manual is to be read in conjunction with the Product Specifications & Assembly manual

SECTION NO.	DESCRIPTION	PAGE NO.
<b>SECTION 1 – SYSTEM DETAILS</b>		<b>1.2.2</b>
	PART A – OVERVIEW	1.2
	PART B – DEDUCTIONS	1.3
	PART C – BOM & CUTTING LIST	1.3
	PART D – INSTALLATION SPACE	1.4
<b>SECTION 2 – ASSEMBLY</b>		<b>2.5</b>
	PART A – EDGE SUB-ASSEMBLY	2.5
<b>SECTION 3 – INSTALLATION</b>		<b>3.6</b>
	PART A – INSTALLING EDGE SIDE GUIDES	3.6
	PART B – INSTALLING CHAIN TENSIONER (CHAIN OPERATED SHADES)	3.7

## DISCLAIMER

### INTRODUCTION

This Installation manual has been produced by Rollease Acmeda to supply the necessary information for safe and correct installation of this system.

### INSTALLERS RESPONSIBILITY

Before installing, please read & ensure you understand the safety information and installation instructions as defined in this installation manual.

- If you do not fully understand these instructions, contact Rollease Acmeda for clarification before installing.
- The Installer is responsible to ensure that all installation personnel have been adequately trained on the safe & correct installation and operation.
- The Installer is responsible to ensure that supporting structures are sound and can adequately support the load.
- The fasteners provided are intended for fixing to timber. The Installer is responsible for selecting fasteners that are suitable for other substrates

### SAFETY INFORMATION

- Ensure that electrical works are done only by a LICENSED ELECTRICIAN.
- DO NOT modify any of the components of this system.

### PERSONNEL REQUIREMENTS

Only suitably trained/qualified personnel should undertake installation.

### DISCLAIMER

Rollease Acmeda has used reasonable care in preparing the information included in this document, but makes no representations or warranties as to the completeness or accuracy of the information. Information is supplied upon the condition that the persons receiving the information will make their own determination as to its suitability for their purposes prior to use. Rollease Acmeda assumes no liability whatsoever for any damages incurred by you resulting from errors in or omissions from the information included herein. Rollease Acmeda reserves the right to make changes without further notice to any products to improve reliability, function or design.

### COPYRIGHT

COPYRIGHT © ROLLEASE ACMEDA 2017

All rights reserved. No part of this document may be reproduced or utilized in any means, by any means, electronic or mechanical including photocopying, recordings, or by any information storage or retrieval system, without the express permission from Rollease Acmeda.



**PART A - OVERVIEW**

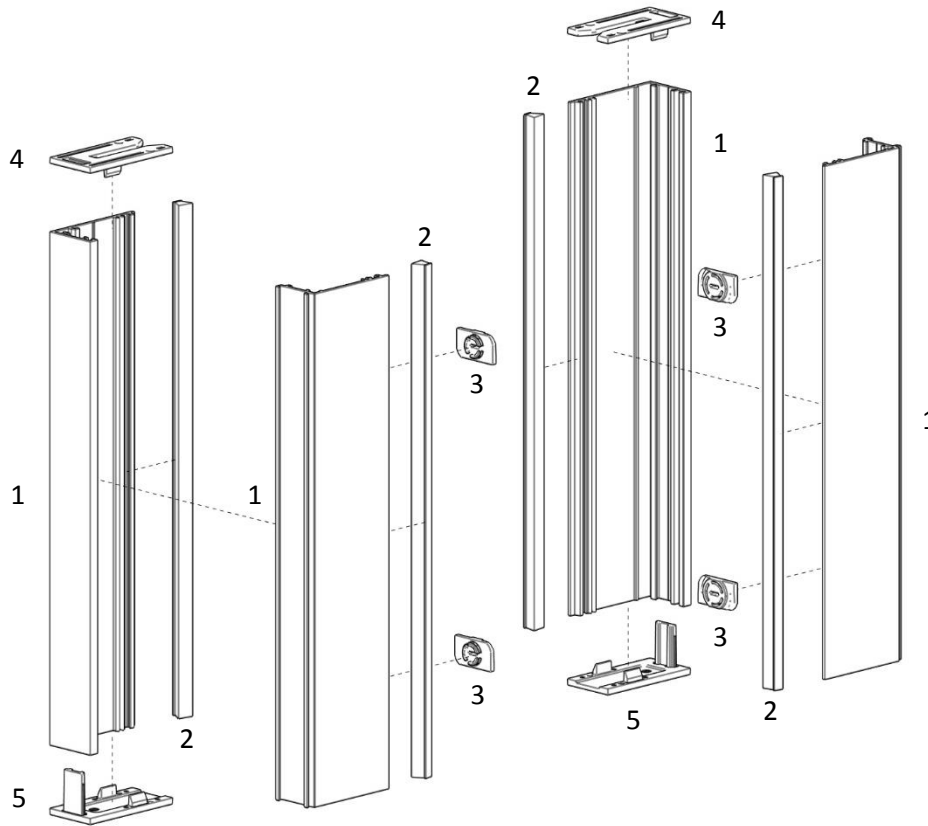

**SYSTEM INDEX**

**EDGE SIDE CHANNELS**

- 1. Edge Light Block | Side Guide
- 2. Fabric Brush T Slot Fit
- 3. Edge Light Block | Side Guide Lock
- 4. Edge Light Block | Side Guide Funnel & Screw Set
- 5. Edge Light Block | Bottom Cap + Screws



## PART B – DEDUCTIONS

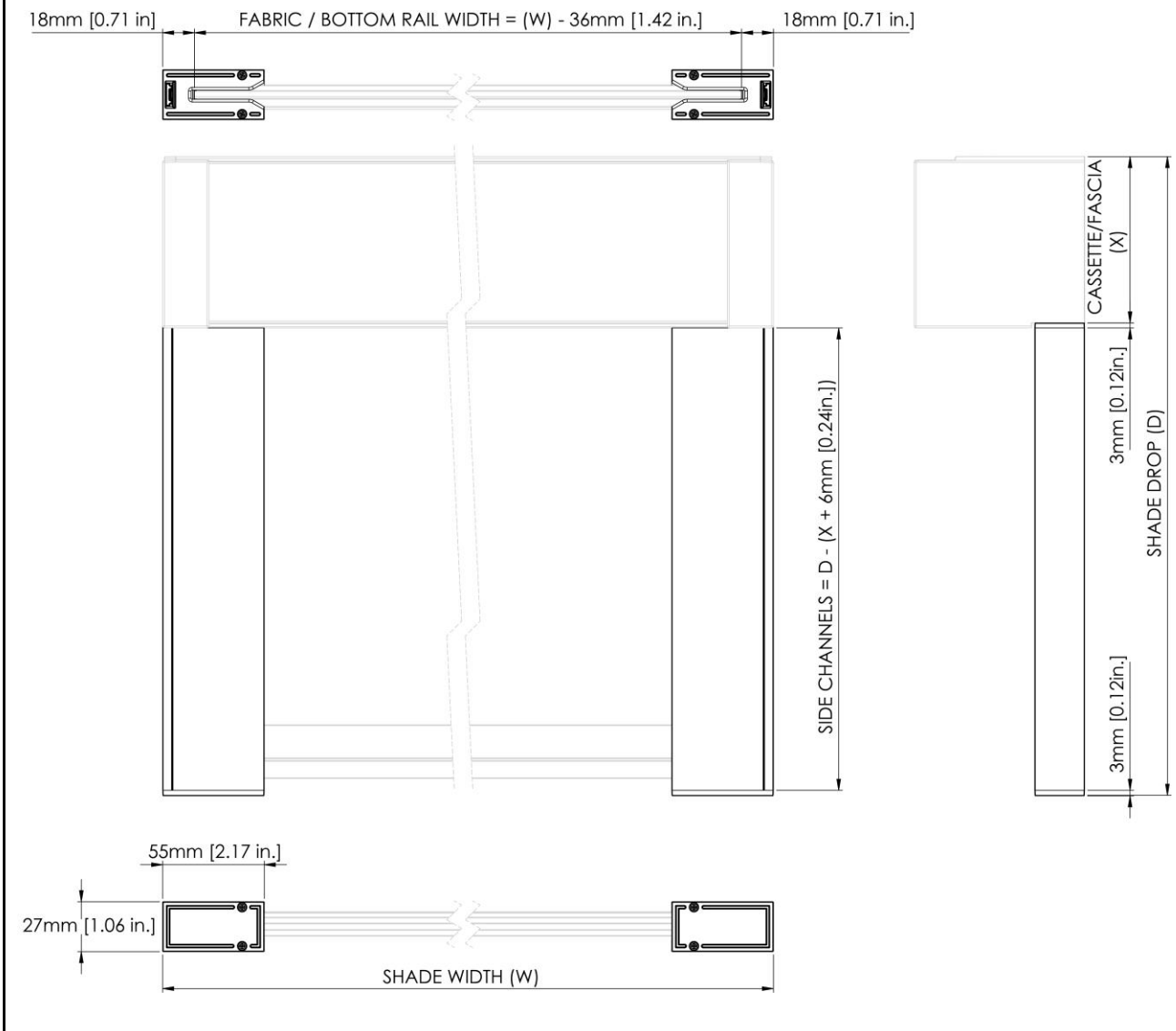

## PART C – BOM & CUTTING LIST

PART NUMBER	DESCRIPTION	U.O.M	QTY	DEDUCTION
RC91-0101-xxxLLL	EDGE LIGHT BLOCK   Side Guide – 2 Piece Set	mm [in]	2	D - (CASSETTE/FASCIA HEIGHT (X) + 6mm [0.24in])
RC91-1001-xxx000	EDGE LIGHT BLOCK   Bottom Cap + screws	Set	1	
RC91-1002-xxx000	EDGE LIGHT BLOCK   Side Guide Funnel & Screw Set	Set	1	
RC91-0302-xxx000	EDGE LIGHT BLOCK   Side Guide Ear	Piece	2	
RC91-0201-xxx000	EDGE LIGHT BLOCK   Side Guide Lock	Piece	4 +	NOTE: 600mm [23.62 in] Max spacing
AW91-1501-xxx000	Fabric Brush T Slot Fit	mm [in]	4	D - (CASSETTE/FASCIA HEIGHT (X) + 6mm [0.24in])

**Additional notes:**

1. Mounting Options for specific systems [eg. mounting brackets/clips] MUST be considered for cutting measurements.



## PART D – INSTALLATION SPACE

### MEASURE & SPECIFY GUIDELINES

To assist with providing seamless communication between the Specifier, Assembler and Installer Rollease Acmeda provides some guidelines to assist with measuring and specifying the Cassette Roller System in order to:

- Identify key information for Assembler and Installer
- Improve efficiency
- Limit the number of re-calls / adjustment required onsite after installation

Please follow the guidelines in the required system installation instructions.

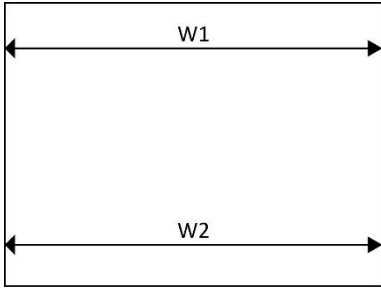
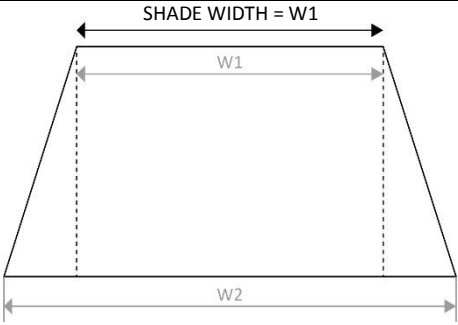
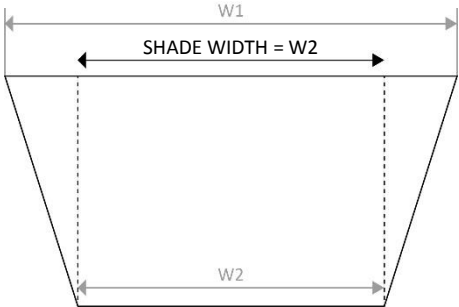
SHADE WIDTH	
	<p>W = Width of Shade</p> <p>If W1 &amp; W2 are equal or within <b>5mm (0.197")</b> of each other, proceed to Part B.</p> <p>If W1 &amp; W2 are not equal or within <b>5mm (0.197")</b> of each other, <b>packing</b> may be required to ensure Channel Guides are level.</p>
MEASURING TIPS	
	



**SECTION 2 – ASSEMBLY**

**PART A – EDGE SUB-ASSEMBLY**

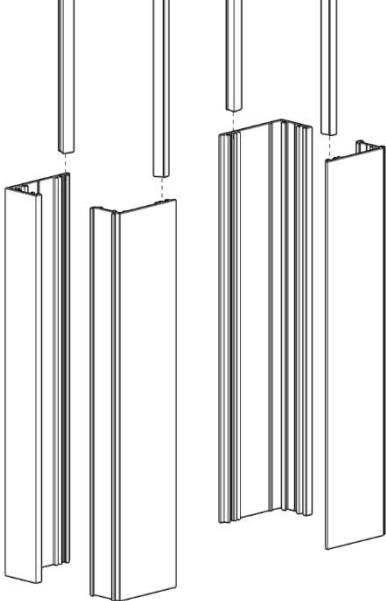
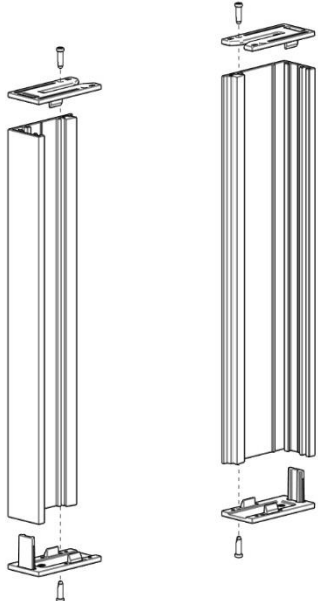
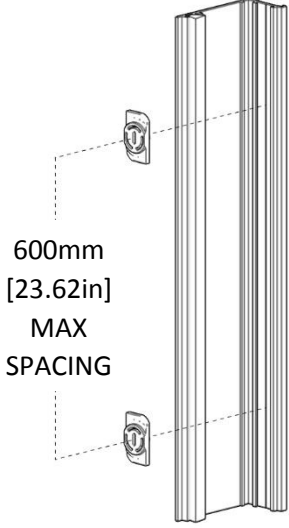
STEP 1 – SLIDE BRUSH INTO EDGE SIDE GUIDE FIXING RAIL + COVER RAIL	STEP 2 – ATTACH FUNNEL & BOTTOM CAP TO EDGE FIXING RAIL WITH SCREWS PROVIDED	STEP 3 – SNAP ON EDGE SIDE GUIDE LOCKS TO SIDE COVER RAIL
		 <p>600mm [23.62in] MAX SPACING</p> <p>NOTE: REPEAT FOR OTHER SIDE GUIDE</p>

**STEP 4 – FINISHED EDGE SUB-ASSEMBLY**

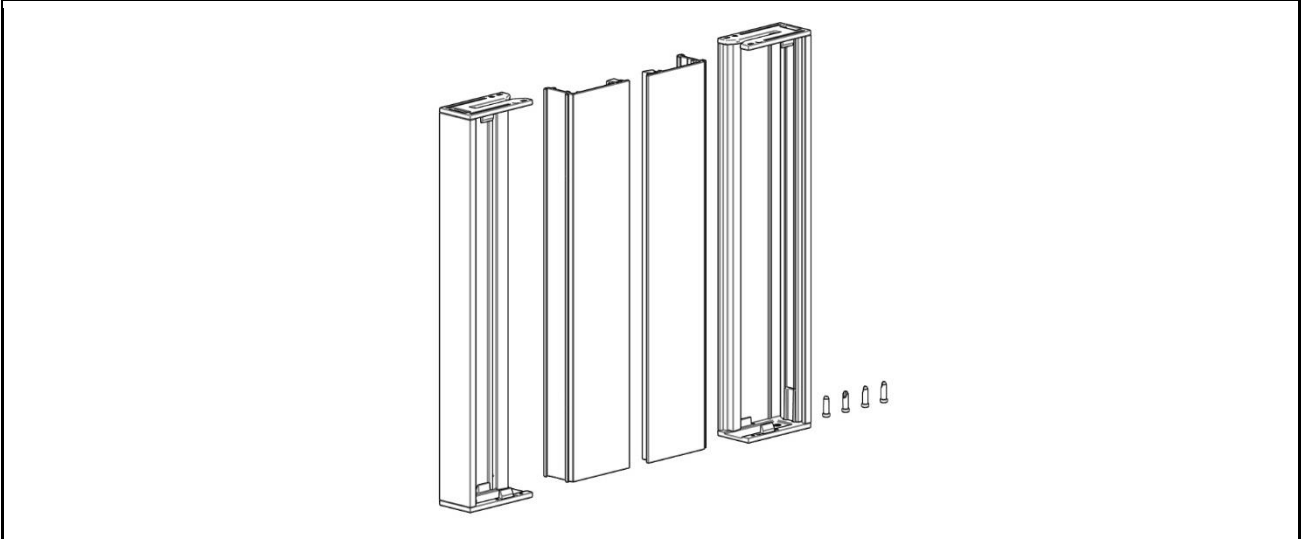

# SECTION 3 – INSTALLATION

## PART A – INSTALLING EDGE SIDE GUIDES

### STEP 1 – LOCATE EDGE SIDE CHANNELS INTO FLUSH POSITION. CF90 USED AS EXAMPLE IN THIS MANUAL.

#### RECESS FIX/INSIDE MOUNT

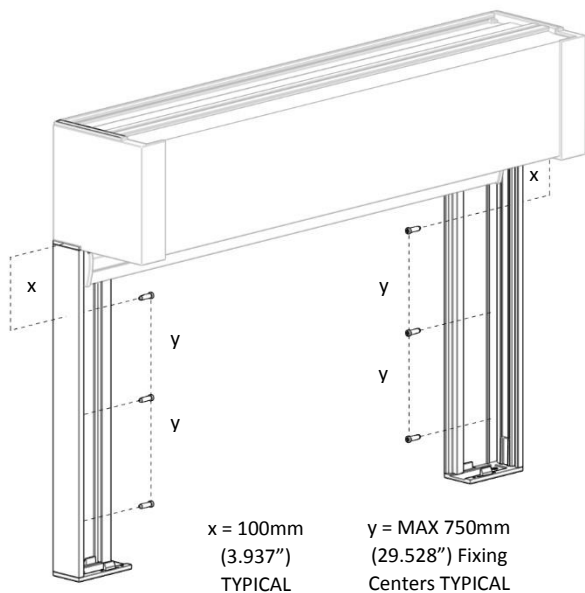

**NOTE:**

- Align with bracket base
- Use grooves in fixing rail to center fixing positions
- **Ensure side guides are vertical and parallel using a level**

#### FACE FIX/WALL MOUNT

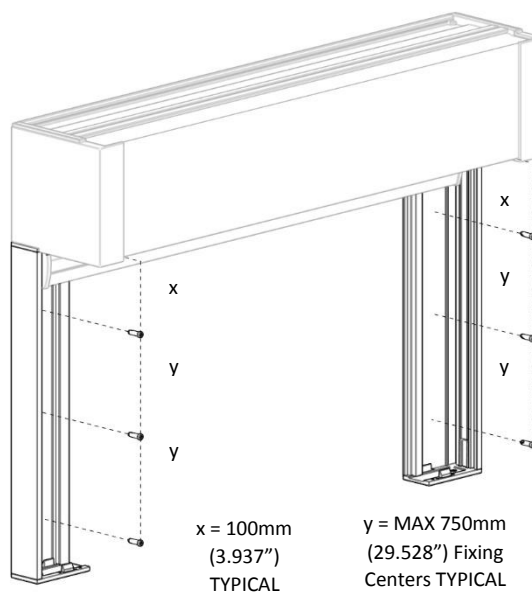

**NOTE:**

- Align with bracket base
- Use grooves in fixing rail to center fixing positions
- **Ensure side guides are vertical and parallel using a level**

### STEP 2 – INSERT EDGE COVER RAILS

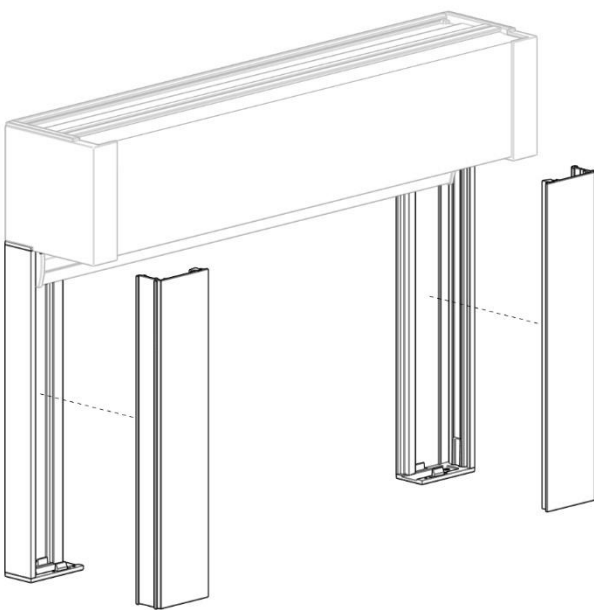

NOTE: Ensure side guide locks are vertical on extrusion

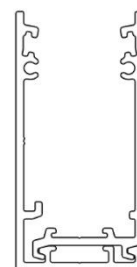
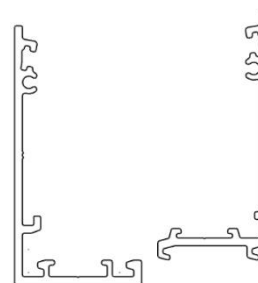

**STEP 3 – USE A FLAT HEAD SCREW DRIVER TO SECURE THE SIDE GUIDES TOGETHER**

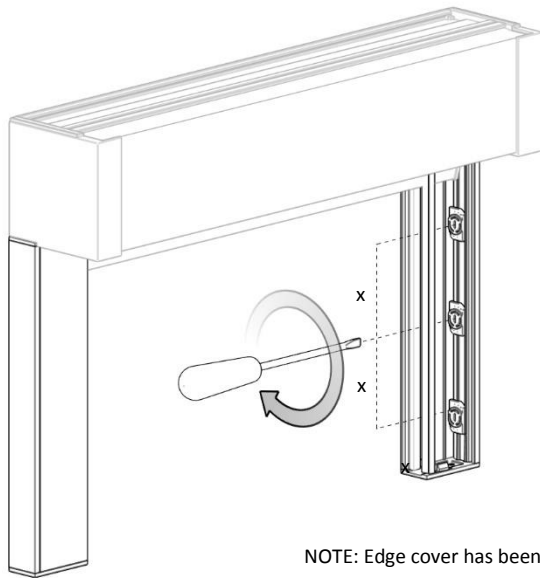

x = MAX  
600mm  
(23.622")  
TYPICAL

NOTE: Edge cover has been removed for clarity

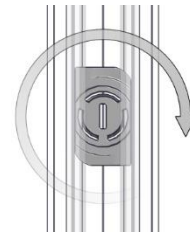

**UNLOCKED POSITION:**  
ROTATE CLOCKWISE TO LOCK

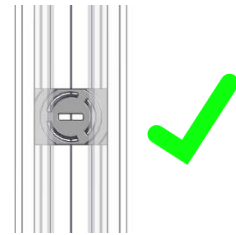

**LOCKED POSITION**

**STEP 4 – TEST SHADE TO ENSURE IT IS OPERATING CORRECTLY**

Run Shade down and up to ensure correct operation

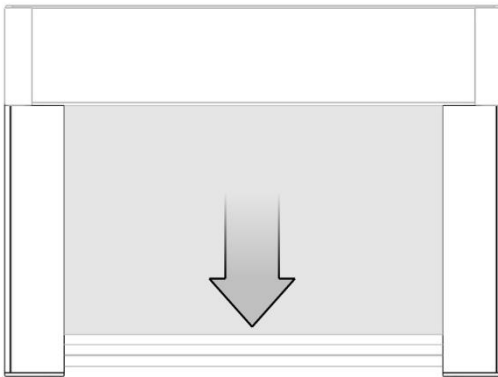

FINISHED EDGE EXAMPLE (CF90)

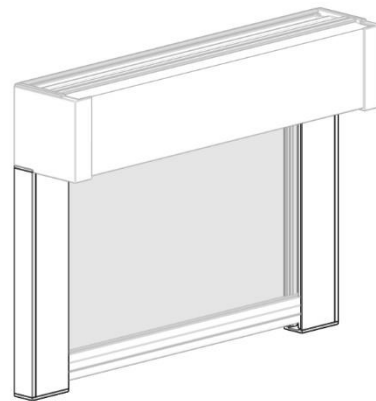

**PART B – INSTALLING CHAIN TENSIONER (CHAIN OPERATED SHADES)**

**STEP 1 – SECURE CHAIN TENSIONER ACCORDING TO CHILD SAFETY LEGISLATION**

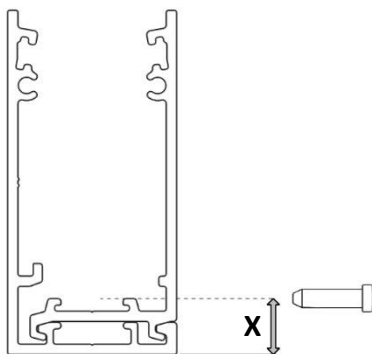

**“X” = Chain Tensioners Fixing Center**

**X = 7–12mm [0.28–0.47in]**

(Depending on Chain Tensioner used)

**IMPORTANT NOTE:**

- All tensioners to be fixed to side guides as specified to ensure bottom rail function is not affected
- To assist with installation, it is recommended to drill pilot holes in the side guide
- When installing Chain Tensioning devices, you must refer to the Chain Tensioning Devices Installation manual

